

SeaShield Marine Systems



BP Refinery installed the Series 2000HD System for the protection of 24" diameter steel piles.



Features

- Minimal surface preparation required (*no abrasive blasting*)
- Fast and easy installation
- Can be applied underwater
- Proven 75 year history of corrosion protection
- One piece jackets
- High impact resistance in aggressive environments
- UV resistant
- Safe to apply and environmentally responsible
- Long maintenance-free service life

Series 2000HD

Heavy-duty pile protection system with marine grade petrolatum tape and an HDPE outercover secured with a bolted system

SeaShield Series 2000HD System provides splash zone protection for steel, concrete and wood structures. The system is ideal for environments where conditions are too severe for paint systems, epoxies and other conventional forms of protection. SeaShield Series 2000HD seals out oxygen and water, effectively stopping corrosion on metal surfaces. The system also prevents spalling and corrosion of steel reinforcement in concrete piles.

The Series 2000HD encapsulates wharf piles, riser pipes and exposed piping in splash and intertidal zones. It accommodates piles with cylindrical and H-Pile configurations, as well as support members, bracing, brackets and other irregular surfaces.

Denso[®]
DENSO NORTH AMERICA



SeaShield Series 2000HD System was used to protect octagonal concrete bridge piles.

Materials

The SeaShield Series 2000HD System stops corrosion by using a proven petrolatum-based tape. The SeaShield Marine Tape forms an anti-corrosion membrane by displacing water and forming a moisture-resistant bond. A tough outercover surrounds this component to protect against weathering and mechanical damage.

Denso Paste S105

Underwater petrolatum paste containing water displacing, corrosion inhibiting and flow control additives. It does not contain volatile organic components. It is applied to badly corroded and pitted steel above and below water prior to the

application of the tape. It displaces water and fills pits and depressions.

Densyl Mastic (optional)

A flexible, putty-like caulking and filler material used to seal irregular shapes and other areas where tape may bridge. Common applications include pile/pilecap interfaces, brackets and flanges. Mastic seals against water and air intrusion and improves contours for tape wrapping.

SeaShield Marine Tape

Synthetic fiber-reinforced tape impregnated and coated with a specially formulated, petrolatum-based compound containing inert fillers and water displacing agents. The tape provides a long-lasting, anti-corrosion membrane for steel and concrete surfaces. Applied spirally, and with sufficient tension, SeaShield Marine Tape displaces water and develops a water resistant bond. It provides the primary corrosion protection in the SeaShield Series 2000HD System.

SeaShield Outercover

A tough, ultraviolet-resistant outercover that provides mechanical protection against the elements and accidental impact. The size of the outercover and thickness of the jacket are customized to meet application requirements. SeaShield outercovers are secured with 316 SS marine grade stainless steel bolts, nuts and washers.



The components of the Series 2000HD System can be applied under water with minimal surface preparation.

Find Out More

For further details please refer to the Engineering Specifications for SeaShield Series 2000HD or call 1-888-821-2300.

Denso[®]

DENSO NORTH AMERICA

HOUSTON:
9747 Whithorn Drive,
Houston, Texas,
U.S.A. 77095
Tel: 281-821-3355
Fax: 281-821-0304

TORONTO:
90 Ironside Crescent,
Unit 12, Toronto,
Ontario, Canada M1X1M3
Tel: 416-291-3435
Fax: 416-291-0898

e-mail: info@densona.com

www.denson.com

A Member of Winn & Coales International





Engineering Specifications for **SeaShield Series 2000 HD** Steel and Concrete Pile Protection

1.0 Scope

- 1.1 This specification may be used for the materials and application of Denso SeaShield Series 2000 HD for protection of steel and concrete piles.
- 1.2 The Engineer shall select appropriate sections of the specification to insure that the specification is comprehensive for specified work.

2.0 General Requirements

- 2.1 Contractor shall comply with all written recommendations of the manufacturer regarding application of the specified system.
- 2.2 The manufacturer of specified materials shall be Denso North America, 9747 Whithorn Drive, Houston, TX 77095, Telephone: 281-821-3355 or 90 Ironside Crescent Unit 12, Toronto, Ontario, Canada M1X1M3 Telephone: 416-291-3435.

E-mail: info@densona.com

3.0 Materials

- 3.1 Denso S105 Primer
 - 3.1.1 The Denso S105 Paste shall be comprised of saturated petroleum hydrocarbons (petrolatum), inert fillers and passivating agents.
 - 3.1.2 The paste is used to displace moisture, passivate surface oxides and fill surface imperfections.
 - 3.1.3 The Denso S105 Paste shall meet the physical specification values listed on the specification sheet.
- 3.2 Denso Mastics
 - 3.2.1 The Denso Mastics shall be comprised of saturated petroleum hydrocarbons (petrolatum), inert fillers, reinforcing fibers and thermal extenders. Variations may contain beads of cellular polymer and flow control additives.

- 3.2.2 Denso Mastics shall be cold applied self supporting Mastic for molding around irregular shaped fittings to provide a suitable profile for applying the SeaShield Tape.

- 3.2.3 The physical specification values shall meet the values given on the specification sheet for the type of Denso Mastic required.

3.3 SeaShield Marine Tapes

- 3.3.1 The SeaShield Marine Tape shall be comprised of a non-woven synthetic fabric carrier fully impregnated and coated with a neutral petrolatum based compound with inert siliceous fillers and inhibitors.

- 3.3.2 The SeaShield Marine Tapes shall have a character stable in composition and plasticity over a wide temperature range. The tape shall be non-hardening and non-cracking. The tape shall accommodate vibration and extreme movement of substrate. Superficial oxidation renders surface less tacky. Highly resistant to mineral acids and alkalis.

- 3.3.3 The SeaShield Marine Tape shall meet the physical specifications values listed on the specification sheet.

3.4 SeaShield Outercover

- 3.4.1 The SeaShield Outercover shall be comprised of High Density Polyethylene (HDPE). It shall be new, seamless virgin material. Use of reprocessed resin is prohibited. The sheet shall be uniform throughout, free from dirt, oil and other foreign matter and free from cracks, creases, wrinkles, bubbles, pin-holes and any other defects that may affect its service.

- 3.4.2 The Outercover shall be 80 mils thick to prevent damage to underlying tape. The outercover will be custom fabricated to the desired length and diameter of the pile. SeaShield Fasteners will be spaced evenly depending on size and length of outercover.

3.4.3 Physical properties of the outercover shall meet or exceed the minimum requirements of the attached product specifications for the SeaShield Outercover.

3.5 SeaShield Fasteners

3.5.1 The SeaShield Fasteners shall be comprised of M10 x 150 mm Bolt, 316 s31 Marine Grade Stainless Steel.

3.5.2 M10 Nyloc Nut, 316 s31 Marine Grade Stainless Steel.

3.5.3 M10 Penny Washer O.D. 35 mm x 1.5 mm thick, 316 s31 Marine Grade Stainless Steel for every nut and bolt there are two washers.

3.5.4 Torque Specification up to 30 mKg or 20 ft.lb.

3.5.5 Space between bolts minimum 300 mm or 12".
Note: A thin coat of anti-sieze shall be applied to bolt prior to tightening to prevent possible galling.

4.0 General Surface Preparation Requirements

- 4.1 Remove weld spatter, sharp points and edges.
- 4.2 Remove marine growth, loose rust, paint and foreign matter by hand and /or power tools cleaning in accordance with SSPC-SP-2, or SP-3, "Hand Tool Cleaning" or "Power Tool Cleaning" respectively.
- 4.3 A hydraulic whirl away or high pressure water blasting may be used to prepare the surface.

5.0 Application of Denso S105 Paste

- 5.1 Apply Denso S105 Paste by hand, brush, glove, rag or roller.
- 5.2 Apply a thin uniform film over the entire surface to be wrapped with SeaShield Marine Tape. (Note: When applying underwater the primer will be less visible on the pile.)

6.0 Application of Denso Mastics

- 6.1 To protect complex surfaces and configurations such as brackets, flanges, valves etc., apply Densyl Mastic or Denso Profiling Mastic by filling and packing to achieve a uniform contour to which tape can be applied without bridging or voids.
- 6.2 Use Densyl Mastic to fill in cavities at the pile/pile cap interfaces.

7.0 Application of SeaShield Tape to a Cylindrical Pile

- 7.1 The SeaShield tape shall be spirally wrapped onto pile using a 55% overlap, which will provide a double thickness of tape throughout. Application shall proceed at the designated low point of the area and proceed upward to the high point creating a weather-board effect.
- 7.2 Hold end of the tape firmly against the starting point and firmly press on the surface. Unroll the tape, keeping the roll close to the surface. Do not get a long lead of tape as it will tend to fold and gap on the surface being wrapped.
- 7.3 Apply sufficient tension to provide continuous adhesion, but do not stretch the tape. As application proceeds, press out all folds and air pockets that may occur.
- 7.4 Maintain a minimum 6" overlap when overlapping one roll with the end of a new roll.
- 7.5 At the completion of each roll, smooth the overlaps by hand in the direction of the spiral to insure sealing of the overlap.

8.0 Application of SeaShield Outercover

- 8.1 Outercover should be custom fabricated to the correct diameter of the pile.
- 8.2 Locate the outercover between the elevations indicated in the specifications and drawings.
- 8.3 Wrap the outercover tight around the pile and align the holes within the fastener bars.
- 8.4 Using the specified nuts, bolts and washers as described in section 3.5, tighten and secure the outercover with a pneumatic wrench to a torque specification of up to 30 kgm or 20 lb.ft.



DENSO NORTH AMERICA

HOUSTON:
9747 Whithorn Drive,
Houston, Texas,
U.S.A. 77095
Tel: 281-821-3355
Fax: 281-821-0304

TORONTO:
90 Ironside Crescent,
Unit 12, Toronto,
Ontario, Canada M1X1M3
Tel: 416-291-3435
Fax: 416-291-0898

www.densona.com

A Member of Winn & Coales International

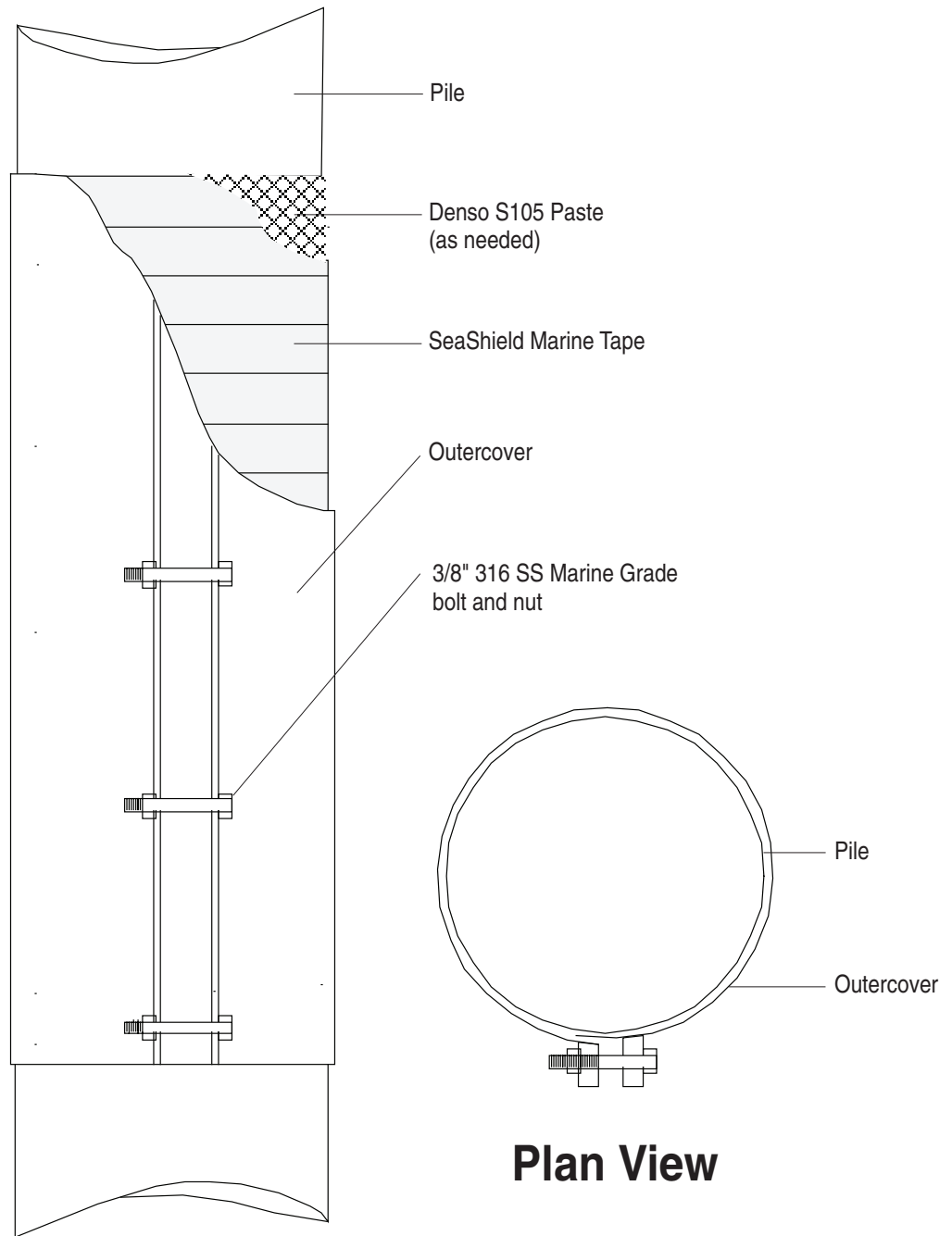

Elevation View

Plan View

Sheet 1
(Not to Scale)

**SeaShield Series 2000 HD
Splashzone Protection System**



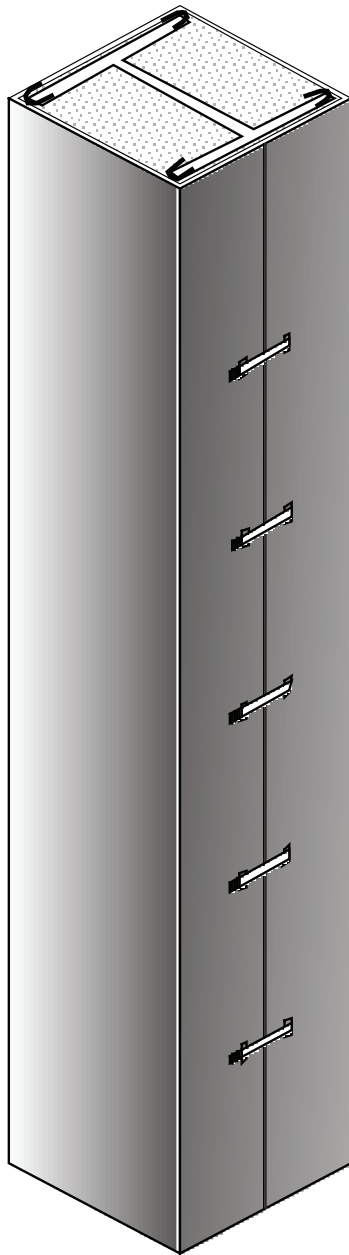

Elevation View

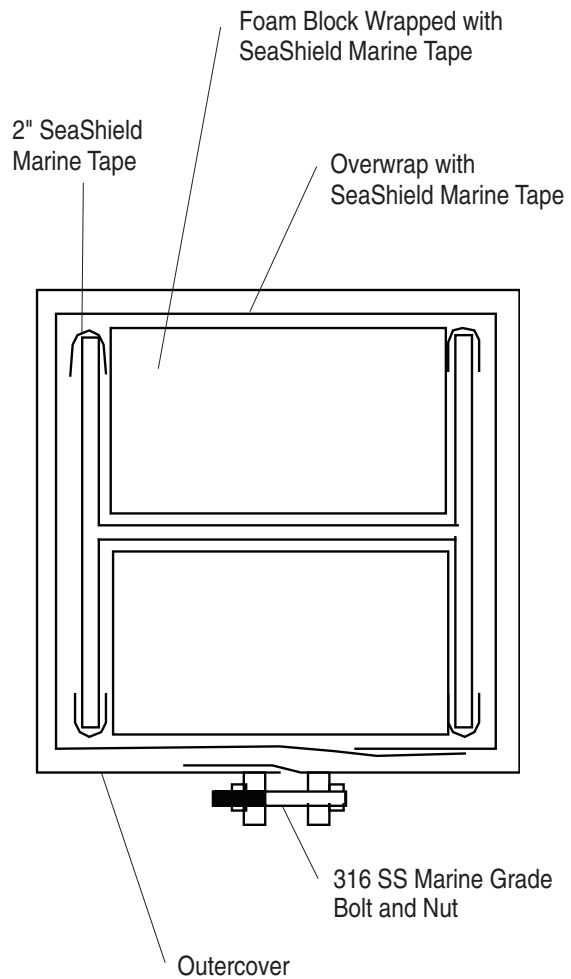

Plan View

Sheet 2
(Not to Scale)

**SeaShield Series 2000 HD H-Pile
Splashzone Protection System**

