



Engineering Specifications for **SeaShield™ Series 500** Steel, Concrete and Timber Pile Protection

1.0 Scope

- 1.1 This specification may be used for the materials and application of SeaShield Series 500 Pile Encapsulation System.
- 1.2 The engineer shall select appropriate sections of the specifications to ensure that the specification is comprehensive for specified work.

2.0 General Requirements

- 2.1 Contractor shall comply with all written recommendations of the manufacturer regarding application of the specified system.
- 2.2 The manufacturer of specified materials shall be Denso North America, 9710 Telge Road, Houston, TX 77095, Tel: 281-821-3355 or 90 Ironside Crescent, Unit 12, Toronto, Ontario, Canada M1X1M3 Tel: 416-291-3435. E-mail: info@densona.com

3.0 Materials

- 3.1 Fiberglass Jacket (SeaShield Fiber-Form)
 - 3.1.1 The fiberglass jacket thickness shall be 1/8" (3 mm) or 3/16" (4.76 mm) thickness, depending on the application and diameter size.
 - 3.1.2 The jacket shall be translucent to provide visual inspection during the injection of the epoxy grout.
 - 3.1.3 The jacket shall have minimum 1-1/4" (31.75 mm) injection ports spaced at intervals not to exceed five feet. To provide even distribution of the epoxy grout, the injection ports shall be placed on alternate sides (can be field installed by contractor).
 - 3.1.4 The jackets shall have stand-offs adhered to the inside of the jacket to provide a minimum of a 3/8" (8 mm) annulus (or per project spec) between the pile and the jacket (can be field installed by contractor). A UV inhibitor shall be included in the polyester resin to provide long-term UV stability.
 - 3.1.5 Please refer to the Denso North America's Fiber-Form Pile Jacket Product Data Sheet for its physical properties.

- 3.1.6 The fiberglass jacket may be manufactured as either a single unit or as two pieces that shall be joined in the field. The jackets can be placed one above the other with the overlapping jacket having a molded open cavity to receive a bottom seal gasket.

3.2 Epoxy Grout

3.2.1 Please refer to the Denso North America's SeaShield 550 Epoxy Grout Product Data Sheet for its physical properties, application methods and mixing guide.

3.3 SeaShield 525 TG Epoxy

3.3.1 The SeaShield 525 TG Epoxy shall be used to adhere the fiberglass vertical seams.

4.0 Equipment

- 4.1 The epoxy grout shall be pre-mixed and pumped through a peristaltic pump or rotor stator pump. The equipment shall be capable of delivering mixed grout through hoses into the jackets at a rate of 1 gpm or greater. Contact pump equipment manufacturer to make sure pump is capable of pumping epoxy grout. The minimum hose diameter should 1-1/4" (31.75 mm) ID. Prior to pumping, all lines shall be primed by circulating 1 gallon (3.8 L) of the SeaShield Hose Lubricant. Contact the pump equipment manufacturer regarding maximum hose length.
- 4.2 Prior to using the pump, all lines shall be primed by circulating 1 gallon (3.8 liter) of the SeaShield Hose Lubricant.

5.0 Material Handling and Storage

- 5.1 Epoxy Grout Components
 - 5.1.1 All liquid epoxy components shall be clearly marked with product name, component designation ("A" or "B"), manufacturer's name, batch number and ratio of component mixtures.
 - 5.1.2 Epoxy components shall be stored in a covered, well ventilated space. The storage temperature shall not be less than 40°F (5°C) and no more than 120°F (49°C). It is recommended to store all components at 68°F to

86°F (20°C to 30°C) for 24 hours prior to use.

- 5.2 Fiberglass jackets on jobsite shall be stored in an area to prevent contamination and minimize distortion.

6.0 Surface Preparation

- 6.1 Prior to application, thoroughly clean and remove marine growth, oil, grease, rust and any other deleterious material which might prevent proper bonding between the pile and epoxy grout. Surface preparation shall be accomplished by grit blasting, power rotary tools or water blasting to provide a surface profile necessary to meet the bond requirements.

7.0 Installation

7.1 Preparation of Fiberglass Jacket

7.1.1 The inside surface of the jacket shall have a roughened / textured surface.

7.1.2 All stand-offs shall be affixed to the jacket at 18" (450 mm) to 48" (1200 mm) intervals (depending on diameter size, length and thickness of jacket in the field) along entire length of jacket. If additional stand-offs are required in the field, SeaShield Stand-off Adhesive can be used to adhere them.

7.1.3 All longitudinal and transverse seams shall be sealed with SeaShield Adhesive Epoxy as described in Section 3.3.1 and fastened with 3/16" (4.8 mm) diameter stainless steel rivets or screws that shall not exceed 6" (150 mm) spacing.

7.1.4 The jacket shall be supported by temporary nylon straps or other means to assure that it will not move or distort during placement of epoxy grout.

7.1.5 A bottom seal shall be fitted on each jacket to prevent any epoxy grout from leaching out of the bottom of the jacket during the placement.

7.2 Epoxy Grout Placement

7.2.1 All three components shall be mixed thoroughly and shall be pumped through a minimum 1-1/4" (31.25 mm) hose ID with a suitable pump such as a peristaltic or rotor stator pump.

7.2.2 A bottom plug of 6" (150 mm) – 12" (300 mm) of epoxy grout shall first be pumped into the lowest injection port. The epoxy grout shall be allowed to cure before proceeding with subsequent lifts.

7.2.3 Once epoxy grout is cured the grout injection shall begin at the bottom injection port and proceed upwards. As the jacket is filled to each port, the lower port shall be capped off and repeated until the top of the jacket is reached. The injection process shall be continuous except when the injection hose is moved from port to port.

7.3 Completion

7.3.1 After the injection process is completed and the epoxy grout has cured, all temporary supports shall be removed.

7.3.2 The top of each fiberglass jacket may be finished with the SeaShield 525 Epoxy.



DENSO NORTH AMERICA

HOUSTON:
9710 Telge Road,
Houston, Texas,
U.S.A. 77095
Tel: 281-821-3355
Fax: 281-821-0304

TORONTO:
90 Ironside Crescent,
Unit 12, Toronto,
Ontario, Canada M1X1M3
Tel: 416-291-3435
Fax: 416-291-0898

www.densona.com

A Member of Winn & Coales International

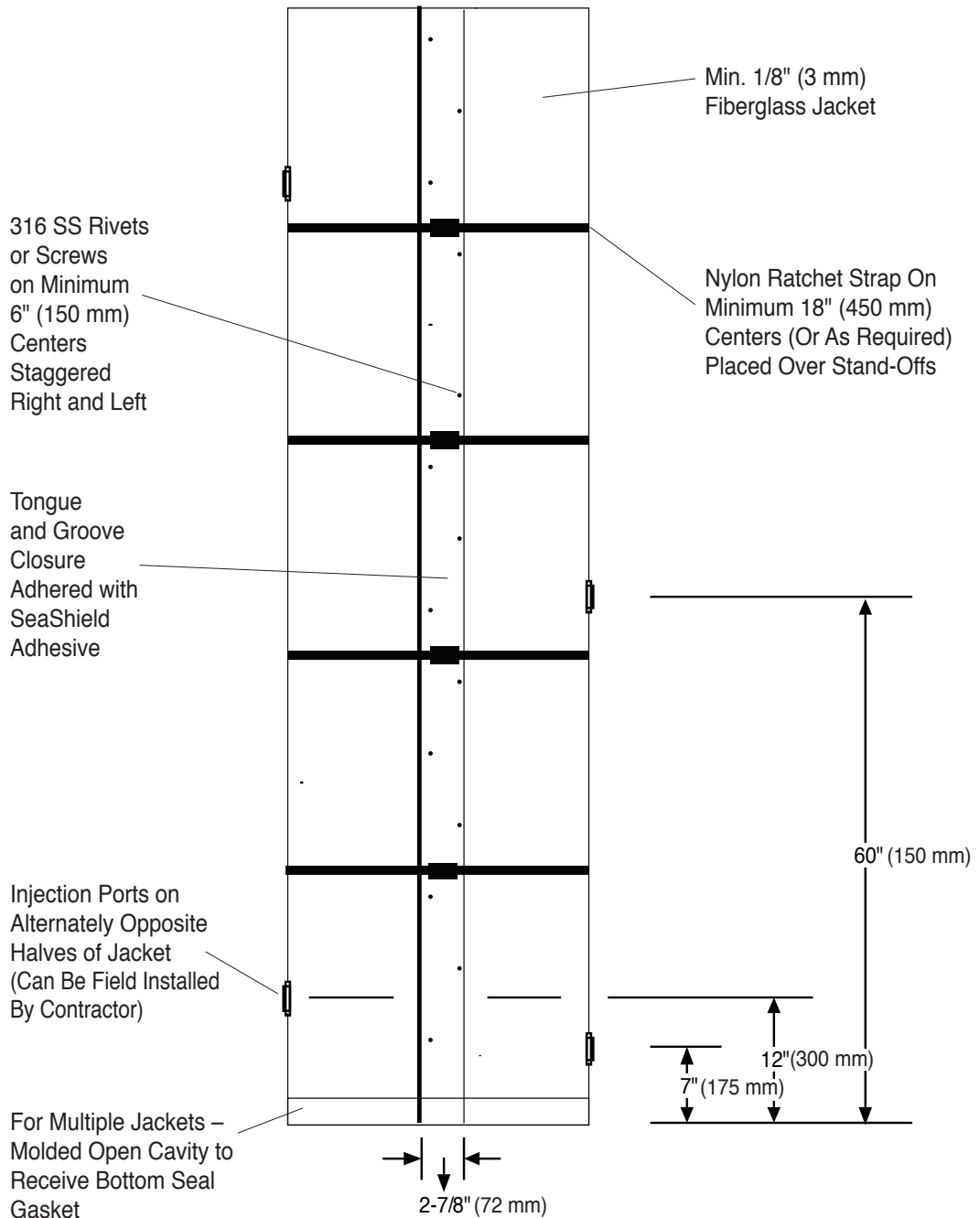

Elevation View

Note: All measurements are approximate and may vary due to diameter and length of jacket.

Sheet 1
(Not to Scale)

**SeaShield Series 500
Pile Encapsulation**



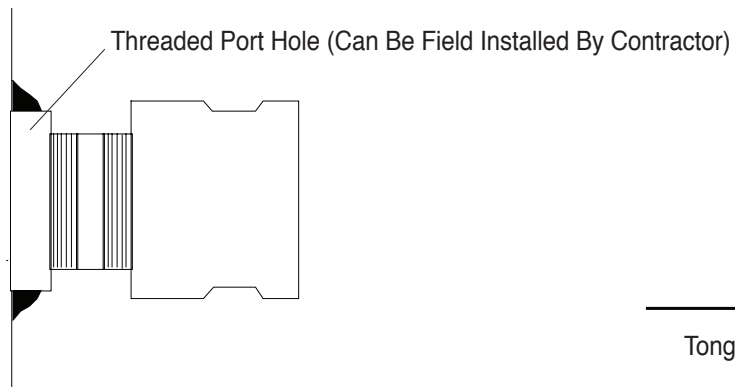

Injection Port Detail



Joint Option Details

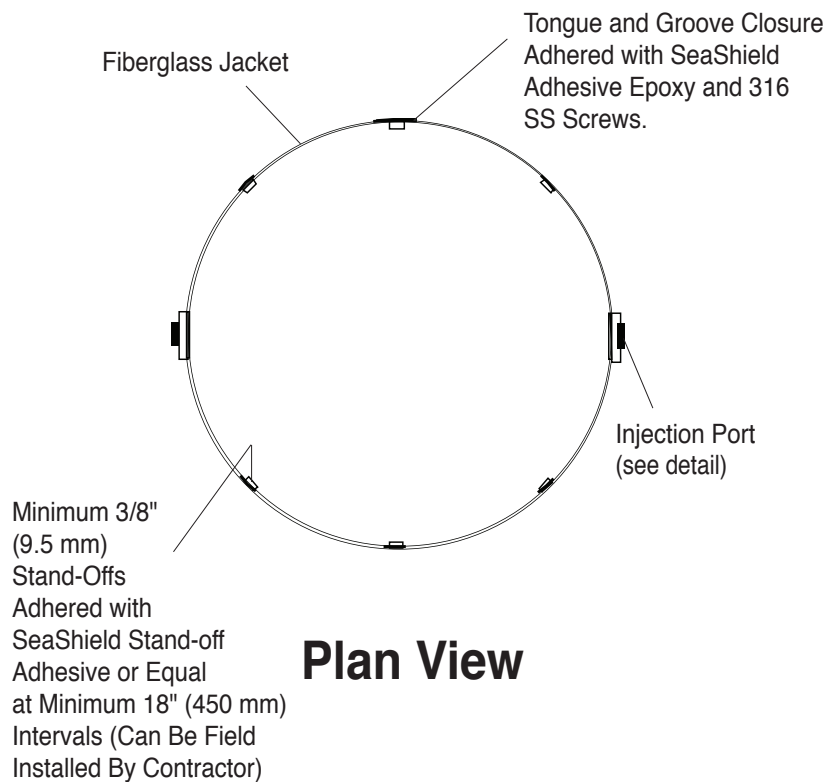

Sheet 2
(Not to Scale)

**SeaShield Series 500
Pile Encapsulation**





Step 1

Position SeaShield Fiber-Form Jacket around pile and seal longitudinal seams.



Step 2

Affix bottom seal gasket with select strapping.



Step 3

Connect grout hose to lower injection port and pump SeaShield 550 Epoxy Grout. Visually check for leaks. Plug upper port(s) and pump grout until it reaches top of jacket. (Upper ports are used only if pumping from lower ports becomes difficult.)



Step 4

(Alternate Pumping Method)

Contractor may choose to inject approximately 6" (150 mm) of SeaShield 550 Epoxy Grout and let cure before moving grout hose to next higher port and pumping remainder of grout. Pumping would then continue until grout reaches top of jacket.

Cured SeaShield 550 Epoxy Grout

Sheet 3

(Not to Scale)

SeaShield Series 500 Grout Placement Sequence



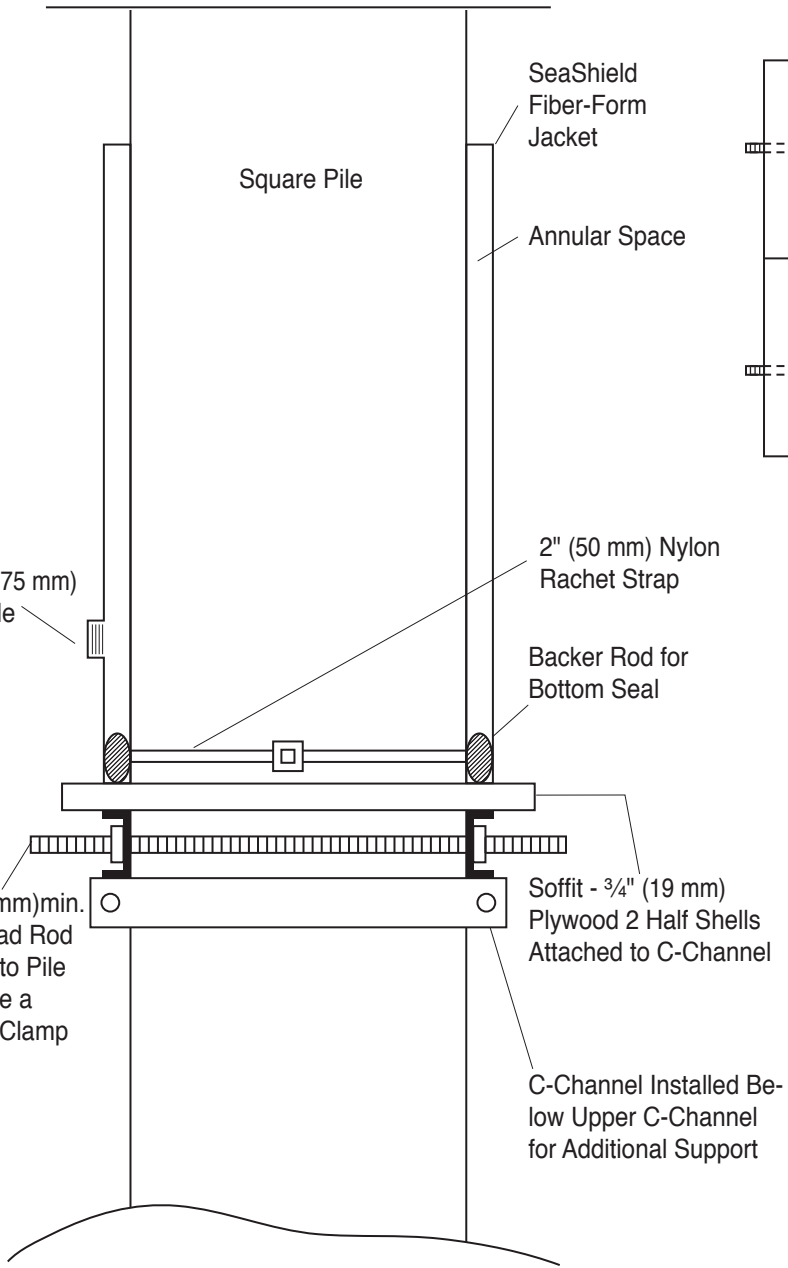

Elevation View

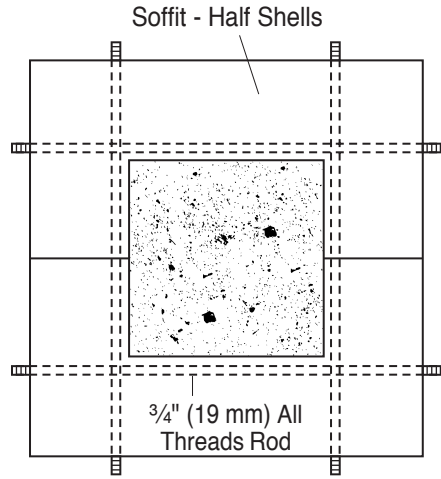

Plan View

Note: All measurements are approximate and may vary due to diameter and length of jacket.

Sheet 4
(Not to Scale)

**SeaShield Series 500
Soffit Detail**

